

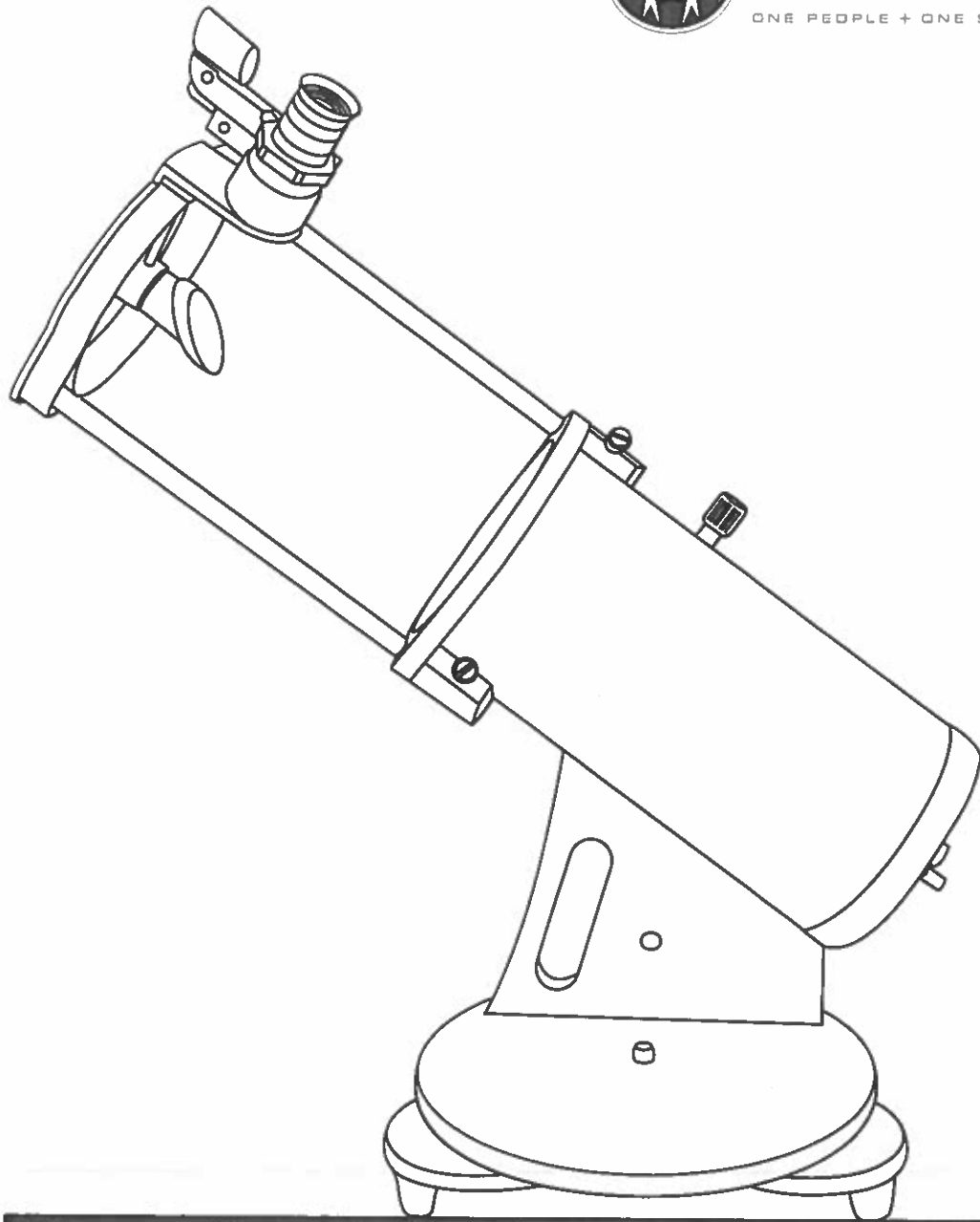

**Astronomers  
Without Borders**  
ONE PEOPLE + ONE SKY



---

# AWB 130 NEWTONIAN

**INSTRUCTION MANUAL**

31100

The AWB 130 Newtonian is sold in the US exclusively by Astronomers Without Borders to raise funds to support its astronomy programs connecting people worldwide through a common interest in astronomy. Celestron imports the AWB 130 Newtonian for Astronomers Without Borders as part of Celestron's commitment to supporting global astronomy programs. Astronomers Without Borders is a US charitable non-profit organization (501(c)(3)).

For more information go to **[www.astronomerswithoutborders.org](http://www.astronomerswithoutborders.org)**.

# TABLE OF CONTENTS

---

<b>TELESCOPE ASSEMBLY . . . . .</b>	<b>3</b>
<b>OPERATING YOUR TELESCOPE . . . . .</b>	<b>4</b>
Positioning the telescope . . . . .	4
Using the Tension Control Knob . . . . .	4
Focusing . . . . .	4
Using the Red Dot Finder . . . . .	4
Removing the telescope tube . . . . .	4
Pointing the Dobsonian . . . . .	4
Calculating the magnification . . . . .	4
Field of view . . . . .	4
<b>OBSERVING THE SKY . . . . .</b>	<b>7</b>
Sky Conditions . . . . .	7
Selecting an Observing Site . . . . .	7
Choosing the Best Time to Observe . . . . .	7
Cooling the Telescope . . . . .	7
Adopting Your Eyes . . . . .	7
<b>PROPER CARE FOR YOUR TELESCOPE . . . . .</b>	<b>8</b>
Collimation . . . . .	8
Cleaning Your Telescope . . . . .	9

## BEFORE YOU BEGIN

Read the entire manual carefully before beginning. Your telescope should be assembled during daylight hours. Choose a large, open area to work to allow room for all parts to be unpacked.

## CAUTION!

NEVER USE YOUR TELESCOPE TO LOOK DIRECTLY AT THE SUN. PERMANENT EYE DAMAGE WILL RESULT. USE A PROPER SOLAR FILTER FOR VIEWING THE SUN. WHEN OBSERVING THE SUN, REMOVE YOUR FINDERSCOPE TO PROTECT IT FROM EXPOSURE. NEVER USE AN EYEPIECE-TYPE SOLAR FILTER AND NEVER USE YOUR TELESCOPE TO PROJECT SUNLIGHT ONTO ANOTHER SURFACE, THE INTERNAL HEAT BUILD-UP WILL DAMAGE THE TELESCOPE OPTICAL ELEMENTS.

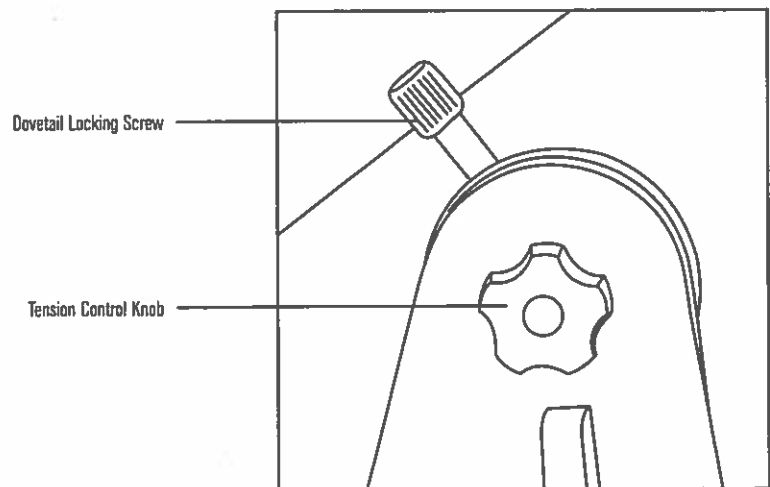
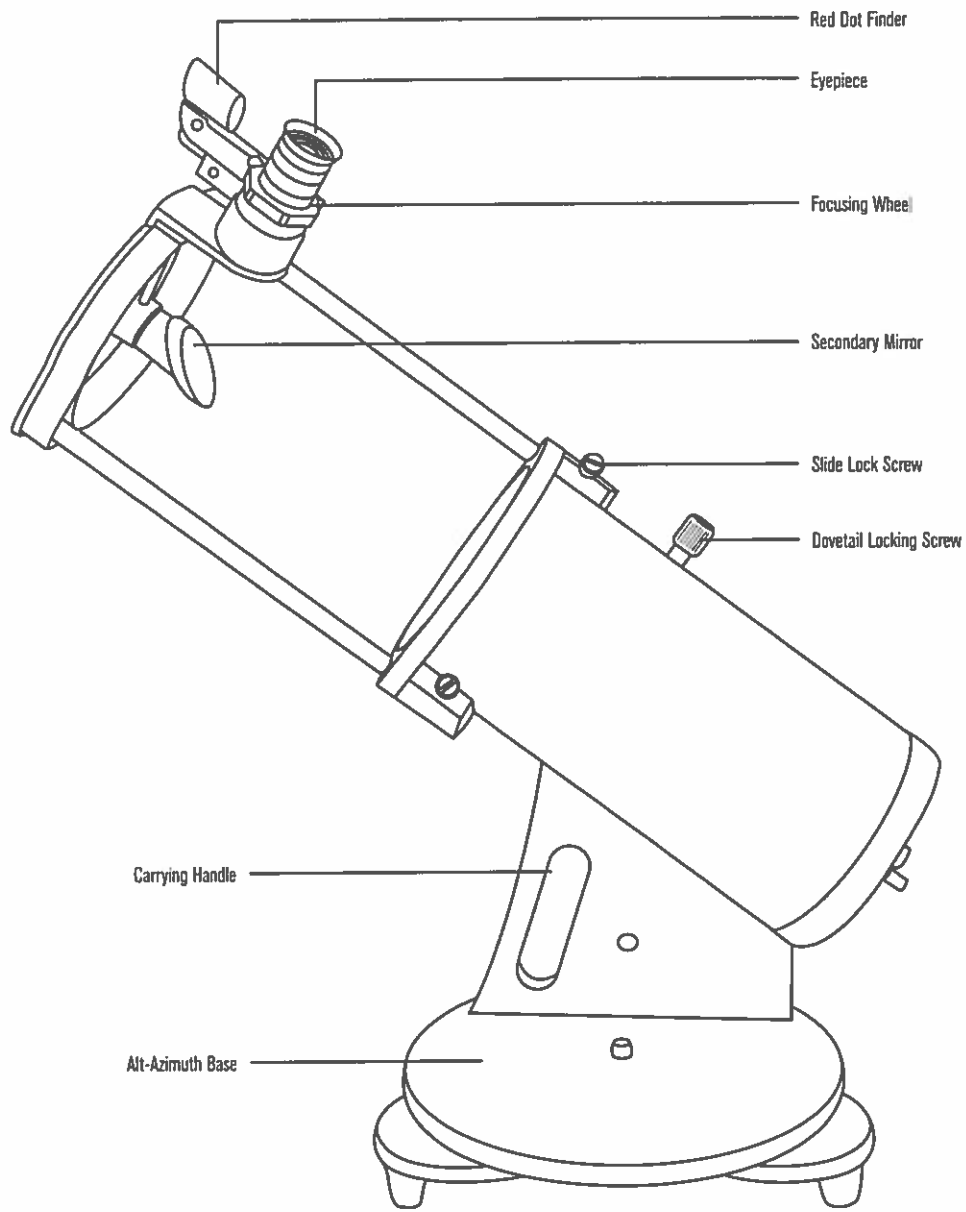

# TELESCOPE ASSEMBLY

**1.** Remove the telescope and accessories from the package.

**2.** Locate the red dot finder. Slightly loosen the screws on the side of the finder. (Fig.a)

Fig.a

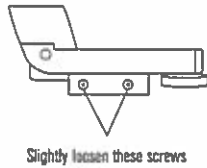

**3.** Locate the small red dot finderscope base near the front opening of the tube. Slide the red dot finder onto the base and tighten the screws to secure it in place. Do not over-tighten the screws. (Fig.b)

Fig.b

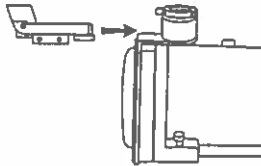

**4.** Locate the eyepiece. Loosen the eyepiece lock screws and slide the eyepiece into the holder. Slightly tighten the screws to hold the eyepiece in place. Do not over-tighten the screws. (Fig.c)

Fig.c

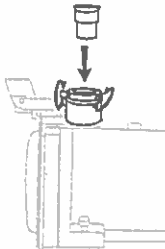

**5.** Fig.d should be how the telescope is stored when not in use. To extend the telescope tube, loosen the two slider lock screws and pull the top part of the telescope assembly up until it clicks in place. (Fig.e) Tighten the slider lock screws. Do not over-tighten.

Fig.d

Loosen the two slider locking screws

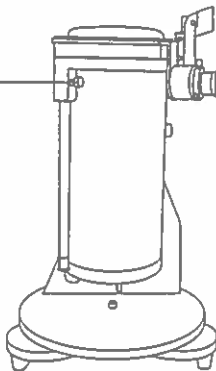

**6.** Remove the dust cap before viewing.

**7.** Position the telescope as in Fig. f with the tube horizontal. Hold the tube firmly and loosen the tension control knob until there is no longer friction holding the tube in place. If the telescope is not balanced the tube will begin to move. To balance the telescope, loosen the dovetail locking screw and slide the tube to a point where the tube no longer moves on its own. Tighten the dovetail locking screw to hold the tube in place. Tighten the tension control knob until the tube requires a slight effort to move to provide a small amount of friction to hold the telescope in place. Do not over-tighten the knob. The tube should still move smoothly with very little effort.

Fig.e

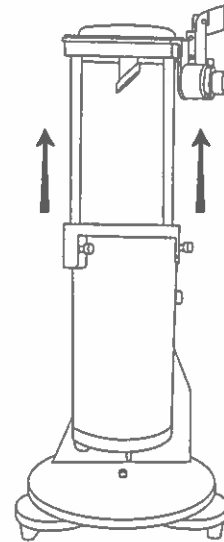
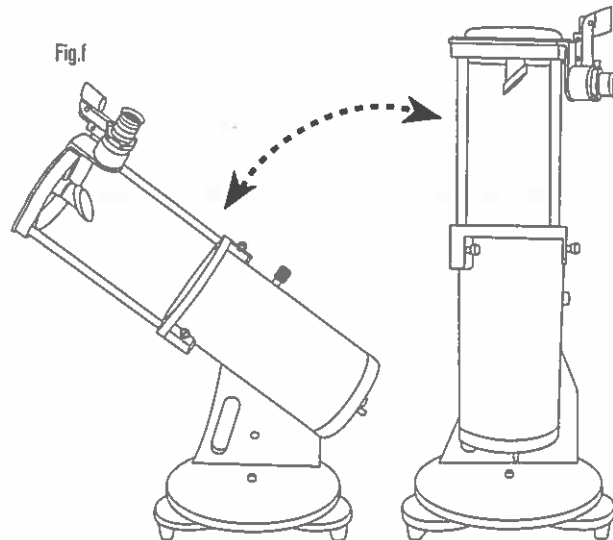

Fig.f



# OPERATING YOUR TELESCOPE

## POSITIONING THE TELESCOPE

To position the telescope to the desired angle, simply move the telescope tube up and down in altitude or swivel the telescope around the base in azimuth. (Fig.f)

## USING THE TENSION CONTROL KNOB

Loosen or tighten the tension control knob to add just enough friction to allow the tube to move easily when nudged but to stay in position when not. It may be necessary to re-adjust the tension control knob when lightweight accessories are added to, or removed from, the tube.

When heavier accessories are used, it may be better to rebalance the scope as described in step 7 on page 3.

## FOCUSING

Slowly turn the focus wheel (Fig.g), one way or the other, until the image in the eyepiece is sharp. The image usually has to be finely refocused over time, due to small variations caused by temperature changes, flexures, etc. This often happens with short focal ratio telescopes, particularly when they haven't yet reached outside temperature. Refocusing is almost always necessary when you change an eyepiece or add or remove a Barlow lens.

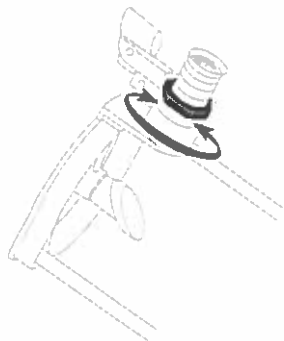

Fig.g

## USING THE RED DOT FINDER

The Red Dot Finder is a zero magnification pointing tool that uses a coated glass window to superimpose the image of a small red dot onto the night sky. The Red Dot Finder is equipped with a variable brightness control, azimuth adjustment control, and altitude adjustment control (Fig.h). The Red Dot Finder is powered by a 3-volt lithium battery located underneath at the front. To use the Finder, simply look through the sight tube and move your telescope until the red dot merges with the object. Make sure to keep both eyes open when sighting.

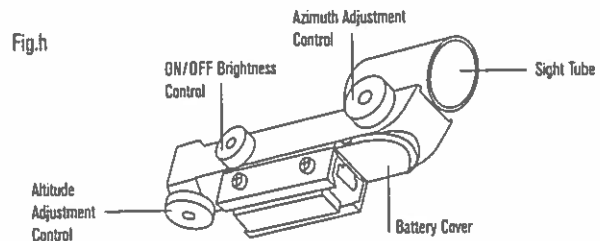

Fig.h

## Aligning the Red Dot Finder

Like all finderscopes, the Red Dot Finder must be properly aligned with the main telescope before use. This is a simple process using the azimuth and altitude control knobs.

1. Open the battery cover by pulling it down (you can gently pry at the 2 small slots) and remove the plastic shipping cover over the battery.
2. Turn on the Red Dot Finder by rotating the variable brightness control clockwise until you hear a "click". Continue rotating the control knob to increase the brightness level.
3. Insert a low power eyepiece into the telescope's focuser. Locate a bright object and position the telescope so that the object is in the centre of the field of view.
4. With both eyes open, look through the sight tube at the object. If the red dot overlaps the object, your Red Dot Finder is perfectly aligned. If not, turn its azimuth and altitude adjustment controls until the red dot is merged with the object.
5. Turn the Red Dot Finder off after use by rotating the variable brightness control counter-clockwise until you hear a "click".

## REMOVING THE TELESCOPE TUBE

The telescope tube can be removed from the mount for storage. Hold the telescope tube in one hand while loosening the dovetail locking knob with the other. Carefully slide the tube off the mount. The telescope tube can be installed on any telescope mount with a dovetail mounting system. You may also install a different short-tube telescope on this portable table-top Dobsonian mount.

## POINTING THE DOBSONIAN

Pointing an altitude-azimuth (alt-az) mounted telescope, such as a Dobsonian, is relatively easy. With the mount level, you can swivel the telescope around on a plane parallel to your horizon and then tilt it up and down from there (Fig.f). You can think of it as turning your telescope in azimuth until it is pointed toward the horizon below a celestial object you want to view, and then tilting it up to the altitude of the object. However, the Earth rotates and therefore the stars are constantly moving, so to track with this mount you have to constantly nudge the optical tube in both azimuth and altitude to keep the object in the field.

In reference material for your local position, the altitude will be listed as  $\pm$ degrees (minutes, seconds) above or below your horizon. Azimuth may be listed by the cardinal compass points such as N, SW, ENE, etc., but it is usually listed in 360 degree (minutes, seconds) steps clockwise from North ( $0^\circ$ ), with East, South and West being  $90^\circ$ ,  $180^\circ$  and  $270^\circ$ , respectively (Fig.j).

Fig.i

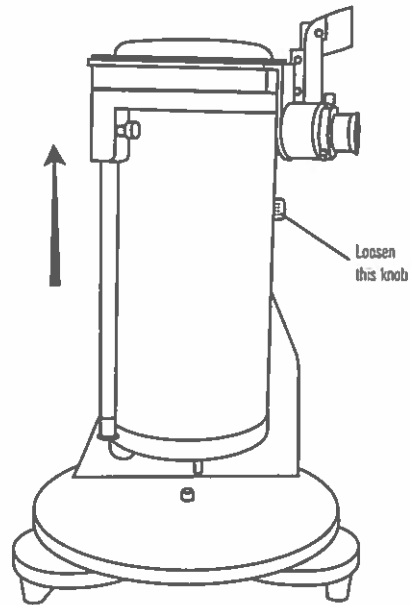
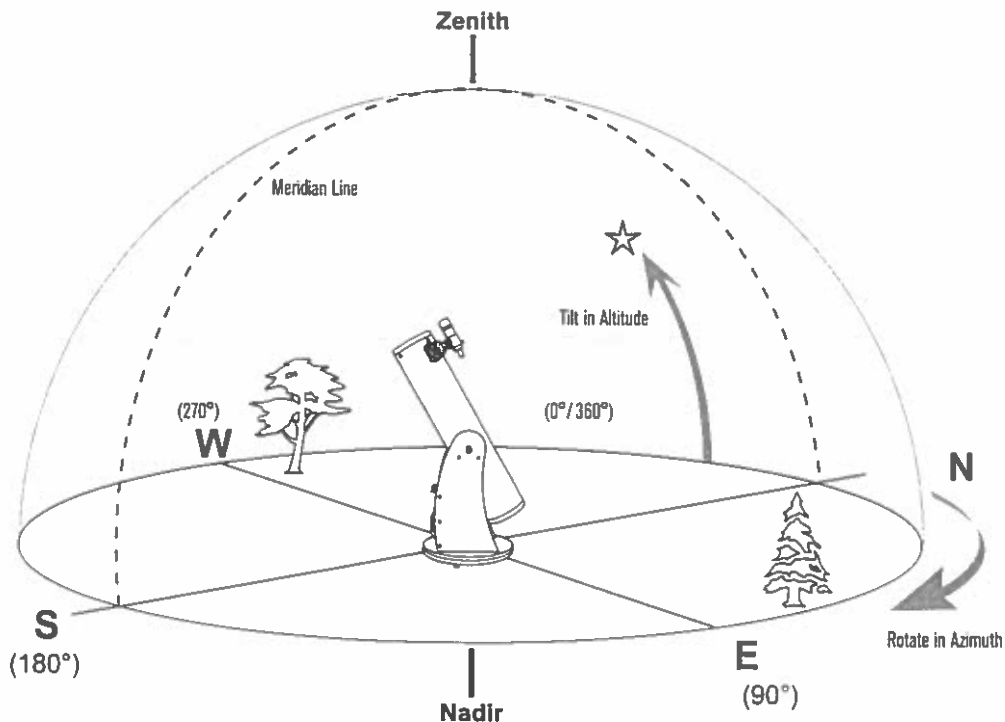

Fig.j



## CALCULATING THE MAGNIFICATION (POWER)

The magnification produced by a telescope is determined by the focal length of the eyepiece that is used with it. To determine a magnification for your telescope, divide its focal length by the focal length of the eyepieces you are going to use. For example, a 10mm focal length eyepiece will give 65X magnification with a 650mm focal length telescope.

$$\text{magnification} = \frac{\text{Focal length of the telescope}}{\text{Focal length of the eyepiece}} = \frac{650\text{mm}}{10\text{mm}} = 65x$$

When you are looking at astronomical objects, you are looking through a column of air that reaches to the edge of space and that column seldom stays still. Similarly, when viewing over land you are often looking through heat waves radiating from the ground, house, buildings, etc. Your telescope may be able to give very high magnification but, depending on the conditions at the time, you may end up magnifying is all the turbulence between the telescope and the subject. The highest usable magnification for this telescope when the sky is very steady is approximately 250x.

## FIELD OF VIEW

The amount of sky you can see through your telescope depends on the design of the eyepiece. Your telescope comes with a 25mm eyepiece that has a field of view of 1.9 degrees and a 10mm eyepiece that has a field of view of 0.7 degrees.

To put this into perspective, the whole moon is about 0.5 degrees in diameter. The 10mm eyepiece, with its 0.7 degree field of view would allow you to frame the whole face of the moon in your view with a little room to spare. Remember, too much magnification and too small a field of view can make it very hard to find things. It is usually best to start at a lower magnification with its wider field and then increase the magnification when you have found what you are looking for. First find the moon then look at the shadows in the craters!



# OBSERVING THE SKY

---

## SKY CONDITIONS

Sky conditions can significantly affect the performance of your telescope in three ways.

- **Steadiness of the air:** On windy days, images of the moon and planets will appear to wave or jump around in the eyepiece; as if you are looking at them through moving water. Nights where winds are calm will offer the best higher magnification views of the planets and the moon. The best way to judge the stability of the atmosphere is to look at bright stars with the naked eye. If they are “twinkling” or rapidly changing colors, the air is unstable and you are better off using lower powers and looking for deep sky objects. If the stars are sharp and not twinkling, the air is stable and should offer great high magnification planetary views.
- **Transparency:** How clear is the air you are looking through? If there is a high amount of humidity in the air, the faint light from galaxies and nebulae can be scattered and diffused before reaching your telescope, causing a loss of brightness in your image. Debris in the air from local forest fires or even distant volcanic eruptions can contribute to large loss of brightness. Sometimes this humidity or debris can help stabilize the air, making for good planetary and lunar images, but the loss of light would make it difficult to see fainter deep-sky objects.
- **Sky Brightness:** The amount of ambient light in the atmosphere can also effect deep-sky observing. How dark the sky is can depend on your local surroundings. In the middle of a city, sky-glow caused by city lights being reflected back to earth from the sky can overpower the faint light from distant galaxies. Getting away from the bright lights of a major city can make the difference between seeing a faint deep-sky object and missing it altogether. Planets and the moon are plenty bright enough on their own so the effect on observing them is minimal.

## SELECTING AN OBSERVING SITE

If you are going to be observing deep-sky objects, such as galaxies and nebulae, you should consider traveling to a dark sky site that is reasonably accessible. It should be away from city lights, a relatively unobstructed view of the horizon, and upwind of any major source of air pollution. Always choose as high an elevation as possible as this can lower the effects of atmospheric instability and can ensure that you are above any ground fog. While it can be desirable to take your telescope to a dark sky site, it is not always necessary. If you plan to view the planets, the moon or even some of the brighter deep-sky objects, you can do this from any location, such as your own backyard. Try to setup the scope in a location that is out of the direct path of streetlights or house lights to help protect your night vision. Try to avoid observing anything that lies within 5 to 10 degrees over the roof of a building. Roofs absorb heat during the day and radiate this heat out at night. This can cause a layer of turbulent air directly over the building that can degrade your image. It is best if you set your telescope

up directly on a dirt or grassy surface. Setting up on any raised platform such as a wooden deck or a hard surface like concrete or a sidewalk, movements you make may cause the telescope to vibrate.

Observing through a window is not recommended because the window glass will distort images considerably. And an open window can be even worse, because warmer indoor air will escape out the window, causing turbulence which also affects images. Astronomy is an outdoor activity.

## CHOOSING THE BEST TIME TO OBSERVE

Try not to view immediately after sunset. After the sun goes down, the Earth is still cooling, causing air turbulence. As the night goes on, not only will seeing improve, but air pollution and ground lights will often diminish. Some of the best observing time is often in the early morning hours before dawn. Objects are best observed as they cross the meridian, the imaginary line that runs from north to south through a point directly over your head. This is the point at which objects reach their highest points in the sky and your telescope is looking through the least amount of atmosphere possible. Objects that are rising or setting near the horizon will suffer more atmospheric turbulence since you are looking through a much longer column of air. It is not always necessary to have cloud-free skies if you are looking at planets or the moon. Often broken cloud conditions provide excellent seeing.

## COOLING THE TELESCOPE

Telescopes require at least 10 minutes to cool down to outside air temperature. This may take longer if there is a big difference between the temperature of the telescope and the outside air. This minimizes heat wave distortion inside telescope tube (tube currents).

## ADAPTING YOUR EYES

If you are planning to observe deep sky objects at a dark sky site, it is best if you allow your eyes to fully adapt to the dark by avoiding exposure to white light sources such as flashlights, car headlights, streetlights, etc. It will take your pupils about 30 minutes to expand to their maximum diameter and build up the levels of optical pigments to help your eyes see the faint light from a distant target. If you need light to help setup your telescope in the dark, try using a red LED flashlight at as low a brightness setting as possible and avoid looking straight at the light source. This will give you the best chance of capturing those faint deep sky objects.

When observing, it is important to observe with both eyes open. This avoids eye fatigue at the eyepiece. If you find this too distracting, cover the unused eye with your hand or an eye patch. The center of your eye works well in bright daylight, but is the least sensitive part of the eye when trying to see subtle detail at low light levels. When looking in the eyepiece for a faint target, don't look directly at it. Instead look toward the edge of the field of view and the object will appear brighter.

# PROPER CARE FOR YOUR TELESCOPE

## COLLIMATION

Collimation is the process of aligning the mirrors of your telescope so that they work in concert with each other to deliver properly focused light to your eyepiece. By observing out-of-focus star images, you can test whether your telescope's optics are aligned. Place a star in the centre of the field of view and move the focuser so that the image is slightly out of focus. If the seeing conditions are good, you will see a central circle of light (the Airy disc) surrounded by a number of diffraction rings. If the rings are symmetrical about the Airy disc, the telescope's optics are correctly collimated (Fig.g).

If you do not have a collimating tool, we suggest that you make a "collimating cap" out of a plastic 35mm film canister (black with gray lid). Drill or punch a small pinhole in the exact center of the lid and cut off the bottom of the canister. This device will keep your eye centered of the focuser tube. Insert the collimating cap into the focuser in place of a regular eyepiece.

Collimation is a painless process and works like this:

Pull off the lens cap which covers the front of the telescope and look down the optical tube. At the bottom you will see the primary mirror held in place by three clips 120° apart, and at the top the small oval secondary mirror held in a support and tilted 45° toward the focuser outside the tube wall (Fig.h).

The secondary mirror is aligned by adjusting the three smaller screws surrounding the central bolt. The primary mirror is adjusted by the three adjusting screws at the back of your scope. The three locking screws beside them serve to hold the mirror in place after collimation. (Fig.i)

### Aligning the Secondary Mirror

Point the telescope at a lit wall and insert the collimating cap into the focuser in place of a regular eyepiece. Look into the focuser through your collimating cap. You may have to twist the focus knob a few turns until the reflected image of the focuser is out of your view. Note: keep your eye against the back of the focus tube if collimating without a collimating cap. Ignore the reflected image of the collimating cap or your eye for now, instead look for the three clips holding the primary mirror in place. If you can't see them (Fig.j), it means that you will have to adjust the three bolts on the top of the secondary mirror holder, with possibly an Allen wrench or Phillip's screwdriver. You will have to alternately loosen one and then compensate for the slack by tightening the other two. Stop when you see all three mirror clips (Fig.k). Make sure that all three small alignment screws are tightened to secure the secondary mirror in place.

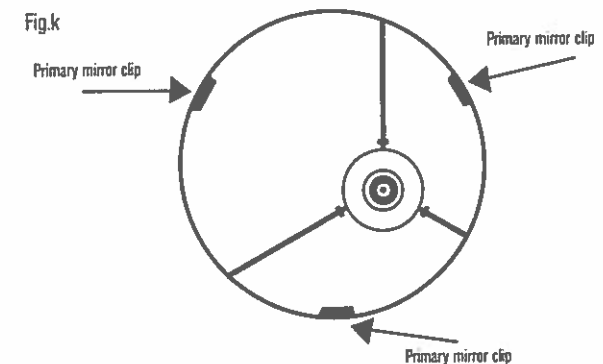
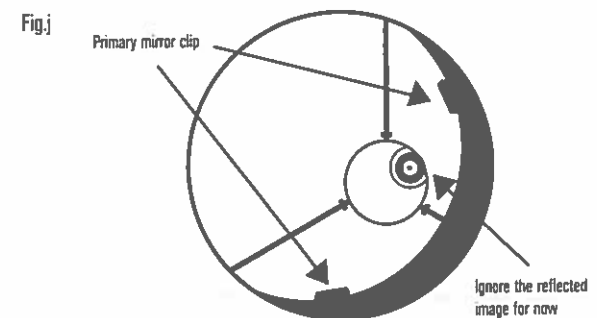
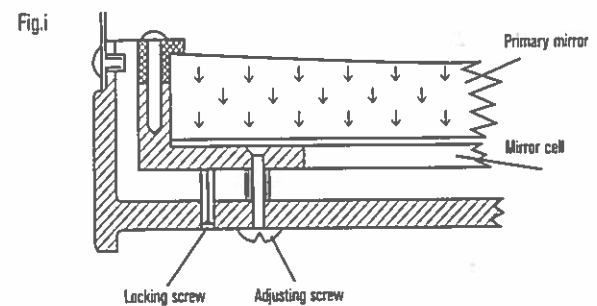
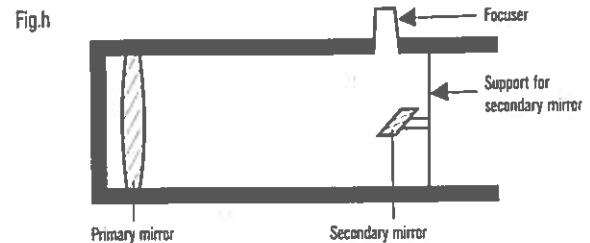
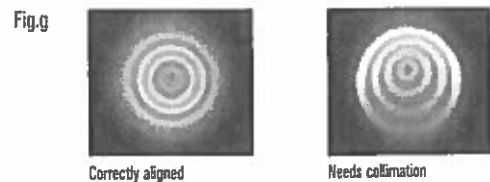

### Aligning the Primary Mirror

There are 3 large bolts and 3 small screws at the back of your telescope. The large bolts are the adjusting screws and the small screws are the locking screws (Fig.p). Loosen the large bolts by a few turns. Now run your hand around the front of your telescope keeping your eye to the focuser, you will see the reflected image of your hand. The idea here being to see which way the primary mirror is deflected, you do this by stopping at the point where the reflected image of the secondary mirror is closest to the primary mirrors' edge (Fig.q).

When you get to that point, stop and keep your hand there while looking at the back end of your telescope, is there an adjusting screw there? If there is you will want to loosen it (turn the screw to the left) to bring the mirror away from that point. If there isn't a adjusting screw there, then go across to the other side and tighten the adjusting screw on the other side. This will gradually bring the mirror into line until it looks like Fig.r. (It helps to have a friend to help for primary mirror collimation. Have your partner adjust the adjusting screws according to your directions while you look in the focuser.)

After dark go out and point your telescope at Polaris, the North Star. With an eyepiece in the focuser, take the image out of focus. You will see the same image only now, it will be illuminated by starlight. If necessary, repeat the collimating process only keep the star centered while tweaking the mirror.

### CLEANING YOUR TELESCOPE

Replace the dust cap over end of telescope whenever not in use. This prevents dust from settling on mirror or lens surface. Do not clean mirror or lens unless you are familiar with optical surfaces. Clean finderscope and eyepieces with special lens paper only. Eyepieces should be handled with care, avoid touching optical surfaces.

Fig.p

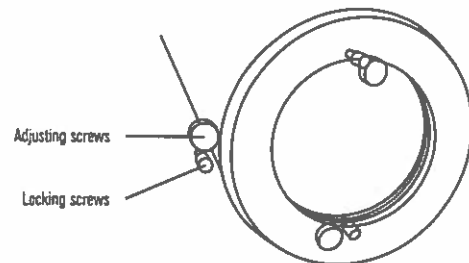

Fig.q

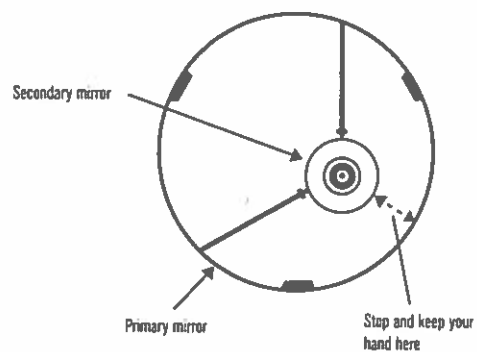
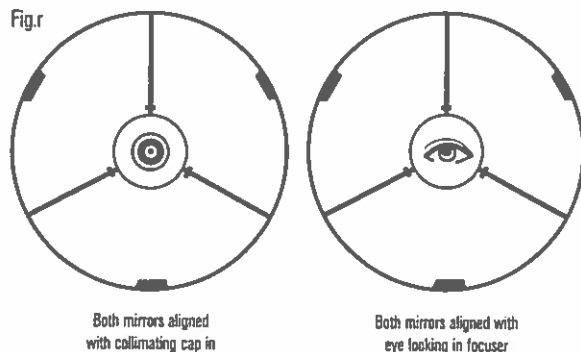

Fig.r



## CAUTION!

NEVER USE YOUR TELESCOPE TO LOOK DIRECTLY AT THE SUN. PERMANENT EYE DAMAGE WILL RESULT. USE A PROPER SOLAR FILTER FOR VIEWING THE SUN. WHEN OBSERVING THE SUN, REMOVE YOUR FINDERSCOPE TO PROTECT IT FROM EXPOSURE. NEVER USE AN EYEPiece-TYPE SOLAR FILTER AND NEVER USE YOUR TELESCOPE TO PROJECT SUNLIGHT ONTO ANOTHER SURFACE, THE INTERNAL HEAT BUILD-UP WILL DAMAGE THE TELESCOPE OPTICAL ELEMENTS.